

Introduction

Consumers are accustomed to receiving documentation when they've purchased particular types of products. The new acquisition of a camera or a sewing machine, for example, typically includes installation requirements, assembly and operating instructions, safety warnings, maintenance guidelines, and warranty information. Often bundled in one booklet, these documents are intended to provide enough information to enable the purchaser to quickly enjoy the merchandise while protecting the manufacturer from exploitation. The reference material must be accurate, comprehensive, and organized. Photographs, diagrams, and drawings are necessary to achieve these objectives.

It's understandable that the textual content of consumer product documentation has evolved. Technology and global influences are examples of this: many consumers use computers and the internet in their daily lives, and manufacturers may now share an international market, no longer restricted by freight, communication, and currency limitations. Gender, ethnic, and age specific assumptions have adapted to current trends and demographics.

But what about the illustrations?

Technical illustrations at the turn of the 20th century

Although the objectives and components of technical illustrations vary, their purpose is common: to visually describe a concept with one interpretation, typically in laymen's terms. The scientific drawings of Leonardo da Vinci (1452-1519) and the architectural drawings of Leon Battista Alberti (1404-1472) are historical examples of visual descriptions of concepts.

(No Model.) C. A. BELL & S. TAINTER. 4 Sheets—Sheet 1.
RECORDING AND REPRODUCING SPEECH AND OTHER SOUNDS.
No. 341,214. Patented May 4, 1886.

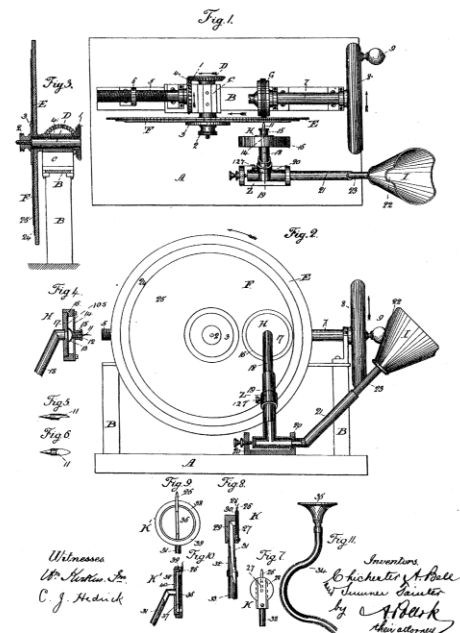
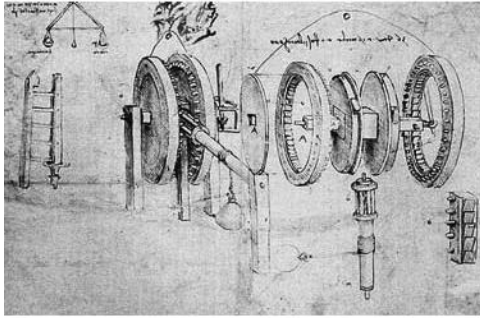
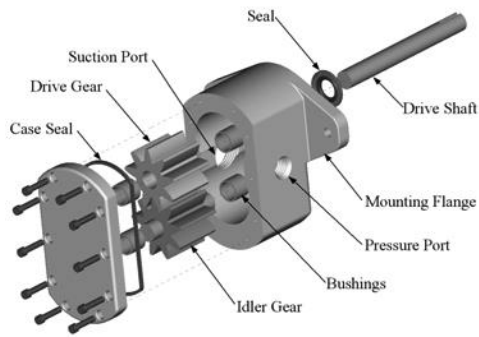

Figure 1. 1886 patent drawing for C.A. Bell and S. Tainter's "Recording and Reproducing Speech and Other Sounds" (sheet 1 of 4).



Figures 2a, 2b, 2c. Examples of an exploded view drawing with callouts, Leonardo da Vinci's exploded view style, and a cutaway drawing.

Styles

The Industrial Revolution brought demand for accurate, comprehensive renderings. U.S. patent drawings for a camera in 1888, a speech recording device in 1886, and virtually all other inventions of the time reveal extraordinary attention to detail and design. Commissioned artists and draftsmen used pen and ink to create drawings “such that they can be readily understood by persons using the patent descriptions” (U.S. Patent Office). The items were drawn in perspective to simulate three dimensions; cross-hatching and varying line weights added the illusion of shadows and highlights.

The artistic qualities of turn-of-the-century patent drawings can also be found in instructional manuals produced at that time. Photos were used occasionally but were uncommon. Items were shown open, closed, on display, and in use. Material and thread might be shown in mid-stitch

on a sewing machine; an animal might be seen within the sight of a gun. Callouts with arrows were used in conjunction with numbers and text found in nearby descriptive paragraphs. Exploded view and cutaway drawing methods of presentation that first appeared during the Renaissance Era were frequently used to clarify assembly and spatial relationships. Full color printing could be found in medical books and textbooks but was cost-prohibitive and unnecessary for use in product documentation.

The same level of detail was applied to supportive items, such as the cabinetry which held a sewing machine. Accompaniments such as bobbins, bullets, and film were included and discussed.

Product Features

A 28-page manual imprinted in 1889 offered instructions, diagrams, and images of Singer Sewing machines in use (Singer Sewing Machine manual 1). Though the text was written in the German language, the callouts that accompanied the drawings were written in English. There were eighteen callouts identifying the important parts of the machine (balance wheel, thread take up cam, tension, etc.). A 24-page manual imprinted in 1898 also offered instructions, diagrams, and images of Singer Sewing machines in use (Singer Sewing Machine manual 2). The text was written in the Russian language but the twenty-nine callouts that accompanied the drawings were also written in Russian. The drawing styles in both examples were detailed and complex, much like the patent drawings.

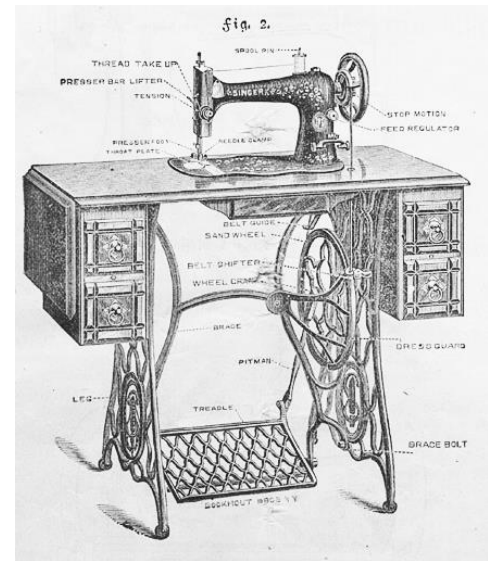
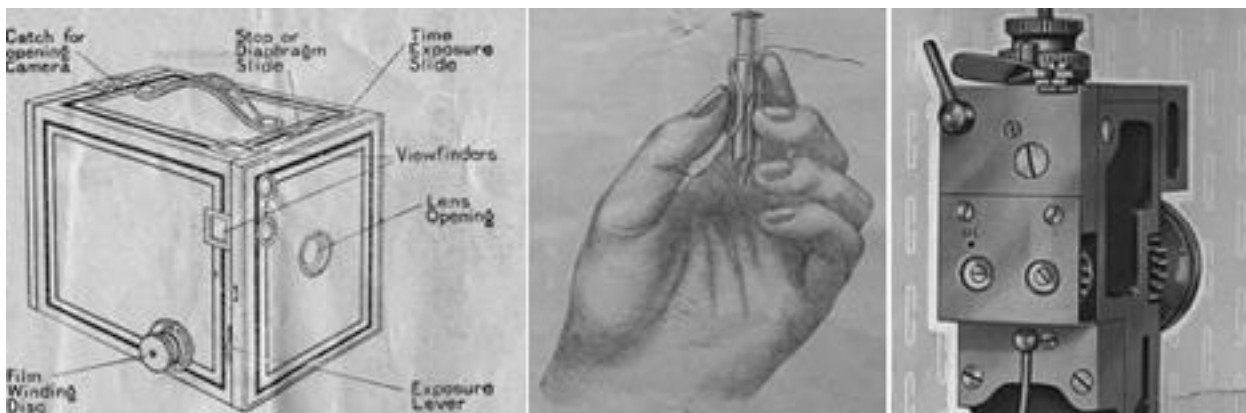

Figure 3. Illustration from Singer Sewing Machine No.2 manual, 1889.

A trade catalog from Howe Machine Company (Howe Sewing Machine) and a bulletin for the James Morrison Company's "Perfection" Wire Stitching machine (Morrison Wire Stitching Machine) displayed the same qualities as the Singer manuals. The stitching machine manual included a photograph of the product in use for general instructions but the details were shown with exquisite drawings.



Figures 4a, 4b, 4c. Excerpts of drawings from manuals, left to right: Brownie No's 2-2a, Singer Sewing Machine No. 2 and the Morrison "Perfection" Wire Stitching Machine No. 5-A.

Many of the illustrations for the No. 2 Kodak Brownie camera (No. 2 Kodak Brownie), on the market from 1901 to 1924, were of the same style and quality as the sewing machines. However, there were also instructions described with photos, and simple cutaway drawings were used to clarify the workings of the interior. Tables showed exposure guidelines. Six callouts pointing to a photograph (exposure slide, slide controlling, exposure lever, winding key, lens opening, and finder) described the overall unit. The combination of image types demonstrates that even a camera manual relies on illustrations, in addition to photographs, for explanation.

Delivery

Technical documentation was printed and supplied on paper, but by the turn of the century both Singer and Eastman Kodak were manufacturing abroad and producing some of their printed matter overseas. The processes of including illustrations within the documents were mechanically the same regardless of the region they were created in. Methods differed in preparing line art and continuous tone, but when printed in large quantities did not significantly impact the cost.

Trade illustrations in the 20th century

A random search on Google Patents for sewing machines, cameras, refrigerators, and handguns from January 1, 1950, to December 31, 1950, showed that high artistic quality and typography was still in place fifty years later. Artists employed cross-hatching, cutaways, and varying line weights to portray depth and dimension. The drawings were simpler, however, and two-dimensional drawings had become common. Perhaps this was due to the sheer volume of work. In 1893, 500,000 design patents were issued; in 1950, 2,500,000 design patents were issued. This corresponded to a more simplistic illustrative style in manufacturer's technical documentation.

Styles

“Instructions for Using SINGER Electric Sewing Machine Model 99” (Model 99 User's Manual) was displayed on the cover of a 3½ x 5¼ inch, stapled, 72-page booklet. Copyrighted in 1953, the typography, graphic design, and logotypes were contemporary and the manual

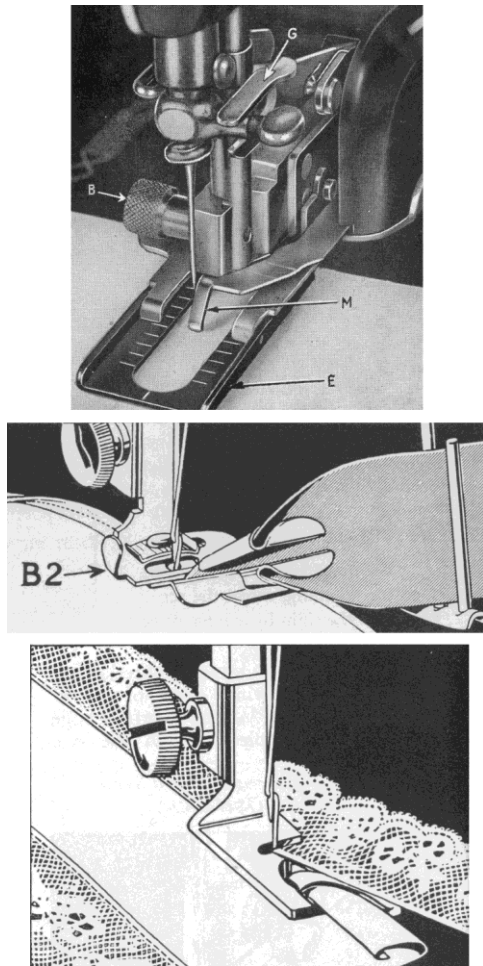

the heading “cleaning the filters”, was drawn with as much precision as those that depicted advancing and cutting the film.

Figure 5. Three different drawing styles within one manual (Singer 99K).

Features

Sewing machines had become feature-rich and complicated by 1953. Explanation was needed – much was packed into a little book. Type within tables was small but white space surrounding the drawings was generous and aided in clarification. Five separate illustrations were devoted to oiling the machine. Fully half of the manual was devoted to the attachments – hemmers, binders, gatherers, edge-stitchers, and rufflers.

A promotional flyer for the Frigidaire Meter-Miser (Frigidaire Meter-Miser) included a cutaway illustration describing the refrigerant control and condenser under the heading “If you are technically minded, here’s how it works.” The three-color flyer boasted “FREON – Safest

included many photographs, drawings, and diagrams. The illustrations were monotone tints of black, simple but detailed black and white line drawings, or elaborate depictions so superbly rendered that they resembled a photograph.

An instruction manual for a View-Master (View-Master Instruction Book) boasting three-dimension photography with a copyright dated 1952 contained contemporary typography and graphic design. Considering the complicated and revolutionary nature of the product, it’s no surprise that it took 32 pages to describe. Nearly all the images were illustrations that included exceptional detail on not only the operation of the camera, but also in what not to do to it. Near the heading “don’t muscle the moving parts”, a hairy wrist holding an oversized wrench is shown. An illustration showing a man blowing on the filter,

Refrigerant known to Mankind” and illustrations accompanied these subheads: “You can breathe it without harm,” “It cannot harm foods,” and “It’s non-inflammable.”

The design of the 40-page 1953 Ford Owner’s Manual (1953 Ford Owner’s Manual) included contemporary typography and illustrative styles. The copy was liberally sprinkled with advice (“...the driver who is continually speeding up, then slowing down, then speeding up again is wasting horsepower and is spending more gasoline dollars”). Nineteen callouts identified the items on the dashboard and instrument panel; drawings provided instructions to change a tire, engage the parking brake, operate the radio, and open the vent windows.

Delivery

The finished size of the Singer sewing machine manual was likely due to the economical process of ganging a print run. By printing multiple pages on one large press sheet and later folding, cutting, and binding them to their finished size, many manuals could be printed at once, reducing the number of imprints. Printing presses and techniques had changed dramatically in the prior decades and demand for large run sizes had increased substantially, which made it possible to economically reproduce continuous tone and color. Full color printing often appeared on the covers of manuals and the body contents within were black and white. Cost savings were achieved by ganging the runs of several manuals and binding the covers and text later in the process.

By the middle of the 20th century, photography had become cost-effective and was useful in describing instructions. Callouts could point at the places in the photo to which they were referring, and photographic processing could alter the highlights and shadows to accommodate dot gain and porous paper. But photographs did not completely replace drawings because there were – and there continue to be – limits in positioning and lighting the components of an item comprised of many parts. Photography and illustrations became equally important tools used to convey clear examples.

Trade illustrations in 2009

In 1950, 2,500,000 design patents were issued; in 2006, 7,000,000 design patents were issued. Visually, U.S. patent drawings vary greatly. Color renderings are allowed, when necessary, and computer-aided drafting and illustration programs are used to produce line art and continuous tone drawings. Although many contemporary patent drawings are well-drawn and informative, they lack the level of detail that technical illustrations possessed at the turn of the century. This is a logical development: accurate, artistic renderings are time-consuming to create, and details become lost in today's cost-effective printing and internet methods of presentation. Product features change rapidly to accommodate market demand and competition; in turn, the associated technical documentation is continuously updated.

Styles

The owner's manual for a Sears Kenmore vacuum cleaner (Vacuum Owner's Manual) includes many precise and well-executed drawings. However, the manual is 5½ inches wide and 8½ inches high; the drawing and its four callouts measure one square inch. No tints are used, and motion is implied with dashed lines. The first half of the manual is written in English, the second half is in Spanish. The callouts reflect each language.

A LaCie external hard drive manual is 4 x 6 inches (LaCie Hard Disk). Printed in blue ink, it offers three tinted illustrations at the front of the manual that serve as reference for the seventeen languages in the body of the 22-page booklet.

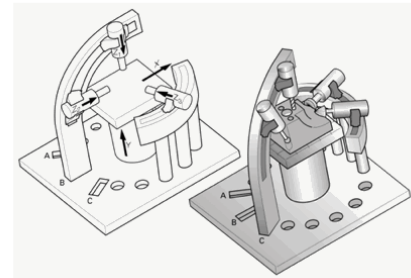
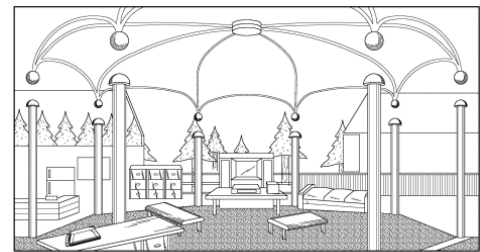
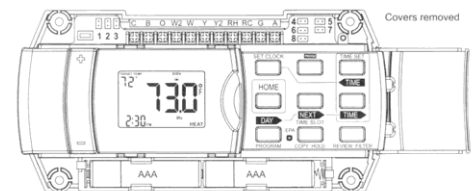

Figure 6. Patent drawings in 2009.



Customer Support: 877-505-2353 or
Visit our website www.ritetemp-thermostats.com
Printed in China

Figure 7. Drawing from the *SOLE thermostat Operation Guide*.

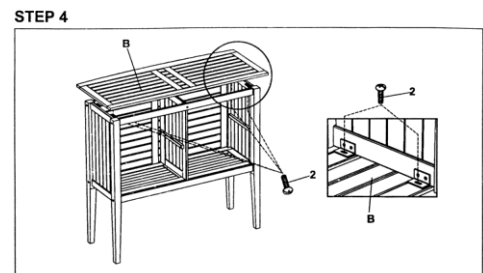

Figure 8. Assembly drawing from the *Kona Outdoor Bar*.

The 5 x 2½ inch, 16-page operation guide for a programmable thermostat (Thermostat Operation Guide) shares the same illustrative style as the vacuum cleaner, but is written entirely in English. The illustrations are small and lack white space; margins are a mere ⅛ inch.

Assembly instructions for a wooden shelving unit (Kona Outdoor Bar) contain a minimal amount of text; it's expected that the product can be assembled from the drawings.

Random observations of several appliance manuals revealed differences in finished size and number of pages but the illustrative styles were the same — simple solid lines, no tints, and minimal surrounding white space.

Features

Two drawings, identifying the main parts and functions of a Brother sewing machine (Brother Operation Manual), offered 17 call-outs and their descriptive paragraphs on one full page of the 68-page document. Drawings, tables, and copy were divided into four sections: Knowing Your Sewing Machine, Sewing Basics, Utility Stitches, and Appendix. Safety instructions and disclaimers preceded the content.

Kodak currently produces six different types of cameras, each with dozens of models and types. The 68-page manual for the Kodak EasyShare CX7530 zoom digital camera (Kodak User's Guide) introduces its main parts and functions with eleven callouts for the front view, three for the side view, fourteen for the back view and four for the bottom view. The drawings are in continuous tone, both in grayscale and in full color. A photograph of the camera appears

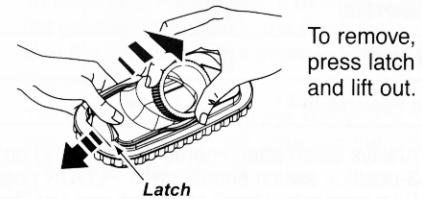

ATTACHMENTS ON WANDS

1. To remove wands from PowerMate, lock wands in straight-up position.

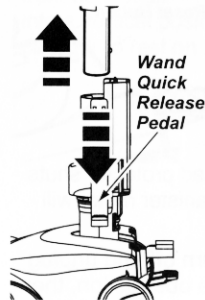
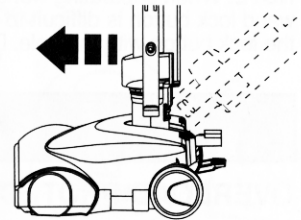

2. Press wand quick release pedal with foot and pull the wands straight up and out of PowerMate.

The PowerMate plug and cord do not have to be removed to use attachments on the wands.

3. Put attachments on wands as needed. See



Figure 9. A drawing from the Kenmore Model 116 vacuum cleaner owner's manual.

on the cover and a few photos appear within the body, describing the interface the user will see when operating the camera. The manual is predominantly comprised of drawings and tables.

A 20-page Kenmore refrigerator manual describes twenty-four “Features at a Glance” but notes that “Features may vary according to model” (Kenmore Refrigerator Use and Care Guide). There are sections and drawings for safety, disposal, installation, door removal and reversal, leveling, temperature control, adjusting the shelves and door bins, the icemaker, and normal operating sounds and sights.

Delivery

Printed versions of product documentation are often included with the product; however, the cost of their printing includes the rapid obsolescence of specifications and the increasing amount of features. Many manufacturers employ various methods of alternative document delivery, each with its own advantages and disadvantages.

CD-ROM

A digital camera might include a CD-ROM that contains the content of the manual and must be viewed on a computer equipped with a CD-ROM drive. The CD is much smaller in mass than a printed manual and reduces the packaging size and weight of the complete product. It can include operating instructions, safety warnings, maintenance guidelines, and warranty information, likely in PDF format, and application software and drivers to install on the end user’s hard drive to expedite the transfer of photos.

Advantages of CD-ROM document delivery:

- There is plenty of digital space on the CD-ROM to offer multiple languages and high-resolution files appropriate for output to a laser printer.
- There is an opportunity to promote other products and accessories with graphics, sound, and video.

- Manufacturing costs are reduced by eliminating printing and shrinking the size and amount of packaging.

Disadvantages of CD-ROM document delivery:

- The burden of creating hard copy is placed on the end user. If the customer wishes to refer to the manual while using the product, such as a camera or a sewing machine in another location than the computer, they'll have to incur the time and cost of printing from the CD to their own laser printer.
- The end user must have a computer, a CD-ROM drive, Adobe Acrobat Reader, and the knowledge to use them.

In addition to acquiring documentation with a new product, potential customers might want to read technical details before the purchase. Also, the original documentation from an appliance or device may have been lost or damaged.

Most manufacturers have websites and offer their manuals online, typically in PDF format. Some charge a fee, some require a proof-of-purchase, and some offer free manuals after registration, which allows a channel of communication for the manufacturer to promote products via e-mail.

Portable Document File (PDF)

Advantages of PDF document delivery:

- It's easy to create a PDF from the same collection of digital files that are sent to offset or quick printers; resolution, font embedding, and indexing can be controlled within the PDF. When prepared in this way, the manual will look onscreen exactly as it does if it's printed to a laser printer or received as a printed manual.
- A PDF can include hyperlinks to more online information.

Disadvantages of PDF document delivery:

- The burden of creating hard copy is placed on the end user.
- Resolution and file size can be problematic. Offering a low-resolution file for a customer to download can result in a manual that is difficult or impossible to read if printed on paper to a typical laser printer. A file high enough in resolution for legibility from a laser printer can be far too large in data size to download quickly, and many of them in one place on a server can slow down the entire webpage.
- The end user's browser settings may prohibit the download of files of more than a nominal amount or from a non-trusted source. Additionally, if the original pagination file includes fonts not found on the recipient's hard drive, an improperly prepared PDF can produce a file that isn't comprehensive onscreen or on paper. Font substitutions can separate captions from graphics, wrap columns of text illogically, or break an illustration so that it appears on two different pages.
- The text of a letter-sized document might be hard to read on a small monitor, such as a laptop, and must be enlarged to view in segments by scrolling. Handheld computers and wireless reading devices, rapidly gaining in popularity, will require offering a PDF that's prepared specifically for those devices.
- Multiple PDFs need to be generated for multiple languages.

Static HTML web pages

Kodak's Advantix C700 Zoom Camera user manual displayed as a static HTML web site can be found online (www.kodak.com/global/en/service/advantix/c700/ownerManual/toc.shtml). Kodak also offers a PDF version of the same manual. The pages contain photographs and illustrations, and the same topics typically found in camera manuals are offered as links from the home page.

Advantages of static HTML document delivery:

- It's easy to navigate to the exact topic with just a click of the mouse, and the list of hyperlinks serves doubly as a table of contents.
- File sizes are small, pages display quickly, and there isn't a need to download or save a file to the hard drive. The manual can quickly be found again by bookmarking the URL in the browser.
- Multiple languages can be managed by hyperlinks or separate websites.

Disadvantages of static HTML document delivery:

- Displaying a list of hyperlinks by topic allows a visitor to choose not to view regulatory or safety information.
- The burden of creating hard copy is placed on the end user.
- The site or portions of it may appear dissimilarly on different platforms and with different browsers.

Web-based image viewers

Nintendo's PlayStation 3 System Software User's Guide (manuals.playstation.net/document/en/ps3/current/manualindex.html) is an example of a dynamically displayed document. There are many ways to create a dynamic site, but their common factor is the presentation of information in an interactive manner.

Like Kodak's static site, Nintendo's PlayStation 3 home page lists a number of links to the same categories found in a traditional, printed user's manual. Visitors can choose their language, sign in to the PlayStation Network, chat via text or voice, and send and receive messages. They can enter a keyword or phrase into a Search feature that draws information from

the database. Choices can be made from an index format, or from a menu which then offers related sub-categories.

Advantages of dynamic online document delivery:

- Dynamic sites draw from a database, separating presentation from content. This results in pages that display similarly in different browsers and different platforms.
- Dynamic sites are easy to navigate and edit, ensuring up-to-date information.
- File sizes are small, pages display quickly, and there isn't a need to download or save a file to the hard drive. The manual can quickly be found again by bookmarking the URL in the browser.
- Manufacturers can enjoy continuing relationships with their customers who utilize the gaming and social network and communication features. This gives them an opportunity to promote new and supportive products and receive valuable feedback; they can entice visitors to return frequently by offering bonus features such as sound, videos, and photos.
- Multiple languages can be accommodated in a number of ways.

Disadvantages of dynamic online document delivery:

- Displaying a list of hyperlinks by topic allows a visitor to choose not to view regulatory, copyright, or safety information.
- The burden of creating hard copy is placed on the end user, and laser prints from dynamic sites without an intentional print page often won't render the desired section of the webpage.
- The initial production of a dynamic website may take months to complete. The employment of many specialists adds significantly to its cost.

Scans

- Collectors of vintage appliances and devices may have just one original manual to distribute to many, often for a fee. Scans are made of each page, arranged in one document and offered as a PDF for download. Occasionally collectors will use an image viewer that allows visitors to turn the pages online, similar to turning pages in a book. Both of these delivery systems are unwieldy because the scans are of large data size.

Conclusion

Adapting drawing styles, tools, and methods is nothing new to the profession of technical illustration, but today's artists are additionally challenged by the deluge of technological advancements and multiple methods of delivery. The illustrations need to render clearly in offset printing, laser printing, and onscreen; they compete for space in small, printed manuals and on computer monitors; and they explain many features and instructions at once. The illustrator will likely prepare multiple versions of the same drawing in order to accommodate an assortment of delivery methods.

The fast pace of technological advancements affects the artist in another way: Illustration, pagination, and drafting programs are frequently improved and expanded, as is the hardware needed to run them. New methods of web design and development are being discovered and shared. Open-source software is gaining acceptance in business environments, bringing the cost of producing a dynamic website to an acceptable sum.

Manufacturers are constantly refining their processes in order to lessen their costs while bringing competitive products to the marketplace. The trend to offer trade literature only in a digital format will continue because of its multiple benefits: reduced production costs; fast updating and editing of content; and promotional opportunities from interacting with end users.

The internet has influenced consumer expectations. Website visitors expect to quickly find what they seek, and they know that with a click of a mouse they can look somewhere else for it. Even if they're looking for documentation of a vintage or antique product, chances are good that a search engine will guide them to discovery.

The suggestion that digital technical documentation will eventually replace print does not account for those without computers, internet access, and computing knowledge. However, the economic law of supply and demand could produce solutions to future challenges. Wireless reading devices are gaining in popularity and may soon offer an acceptable, transportable alternative to printed documentation. Businesses could provide internet search services to those without computing resources.

Whatever course future technological advancements follow, we can be assured that manufacturers will continue to improve their methods of documentation delivery. The need for photos and drawings to describe concepts to humans may never become unnecessary.

Works Cited

“1953 Ford Owner’s manual.” The Old Car Manual Project. December 5, 2009.

<<http://tocmp.com/manuals/Ford/1953/index.htm>>

“Brother Computerized Sewing Machine Operation Manual.” Brother-USA.

<http://www.brother-usa.com/ModelDocuments/Consumer/UsersManual/UM_CE_5000PRW_EN_1444.PDF>

“Frigidaire Meter-Miser” refrigerator. Museum Victoria Collections and Research.

<<http://museumvictoria.com.au/collections/items/1511789/publicity-brochure-frigidaire-electric-domestic-refrigerators-1950>>

“Howe Sewing Machines.” The Smithsonian Libraries Historical Trade Literature Collection.

December 5, 2009. <<http://www.sil.si.edu/DigitalCollections/Trade-Literature/Sewing-Machines/NMAHTEX/0864/>>

“Instructions for Using SINGER Electric Sewing Machine Model 99”. Singer Sewing Machine Company. 1953.

“Kenmore Top-Mount Refrigerator Use and Care Guide.” Sears, Roebuck and Company. 2007.

“Kodak EasyShare CX7530 zoom digital camera user's guide.” Kodak. <<http://www.kodak.com/global/en/service/publications/urg00252toc.jhtml?pq-path=2324>>

“Kona Outdoor Bar Assembly Instructions.” CostPlus World Market Store. 2008.

“LaCie Hard Disk Quick Install Guide.” LaCie USA. 2007.

“Morrison Wire Stitching Machine.” The Smithsonian Libraries Historical Trade Literature Collection. December 5, 2009. <<http://www.sil.si.edu/DigitalCollections/Trade-Literature/Sewing-Machines/SIL/0077/index.htm>>

“No. 2 Kodak Brownie Camera.” The Brownie Camera Page. December 5, 2009. <<http://www.brownie-camera.com/manuals/no2andno2ab/index.shtml>>

“Owner’s Manual, Model 116.27514.” Sears, Roebuck and Company. 2008.

“Operation Guide 6022 ritetemp.” ritetemp Thermostats. 2008.

“Patent Drawing.” United States Patent and Trademark Office. December 5, 2009. <<http://www.uspto.gov/web/offices/pac/doc/general/drawing.htm>>

“Singer Sewing Machines.” The Smithsonian Libraries Historical Trade Literature Collection. December 5, 2009. <<http://www.sil.si.edu/DigitalCollections/Trade-Literature/Sewing-Machines/NMAHTEX/1762/index.htm>>

“Singer Sewing Machines.” The Smithsonian Libraries Historical Trade Literature Collection. December 5, 2009. <<http://www.sil.si.edu/DigitalCollections/Trade-Literature/Sewing-Machines/NMAHTEX/1764/index.htm>>

“Three Dimension Photography”. View-Master Resource. December 5, 2009. <<http://www.vmresource.com/manuals/camera.pdf>>

Appendix

List of figures

Figure 1. United States Patent and Trademark Office. *Patent Drawing*. 1886.

<<http://patimg1.uspto.gov/.piw?Docid=00341214&homeurl=http%3A%2F%2Fpatft.uspto.gov%2Fnetacgi%2FnphParser%3FSect1%3DPTO1%2526Sect2%3DHITOFF%2526d%3DPALL%2526p%3D1%2526u%3D%25252Fnethtml%25252FPTO%25252Fsrchnum.htm%2526r%3D1%2526f%3DG%2526l%3D50%2526s1%3D0341,214.PN.%2526OS%3DPN%2F0341,214%2526RS%3DPN%2F0341,214&PageNum=&Rtype=&SectionNum=&idkey=NONE&Input=View+first+page>>

Figure 2a. Gear pump exploded.png. Wikimedia Commons. January 2005.

<http://en.wikipedia.org/wiki/Exploded_view_drawing>

Figure 2b. Leonardo da Vinci. *Exploded View Drawing*. Wikimedia Commons.

<http://en.wikipedia.org/wiki/Exploded_view_drawing>

Figure 2c. *Cutaway View Drawing*. <http://www.khulsey.com/history.html>

Figure 3. The Smithsonian Libraries Historical Trade Literature Collection.

Illustration from Singer Sewing Machine No.2 manual. 1889.

<<http://www.sil.si.edu/DigitalCollections/Trade-Literature/Sewing-Machines/NMAHTEX/1762/index.htm>>

Figure 4a. The Brownie Camera Page. *No. 2 Kodak Brownie Camera Instruction*

Manual. <<http://www.brownie-camera.com/manuals/no2andno2ab/index.shtml>>

Figure 4b. The Smithsonian Libraries Historical Trade Literature Collection.

Illustration from Singer Sewing Machine No.2 manual. 1889.

<<http://www.sil.si.edu/DigitalCollections/Trade-Literature/Sewing-Machines/NMAHTEX/1762/index.htm>>

Figure 4c. The Smithsonian Libraries Historical Trade Literature Collection.

Morrison "Perfection" Wire Stitching Machine No. 5-A.

<<http://www.sil.si.edu/DigitalCollections/Trade-Literature/Sewing-Machines/SIL/0077/index.htm>>

Figure 5. Singer Sewing Machine Company. *Instructions for Using SINGER Electric Sewing Machine Model 99. 1953.*

Figure 6a. Technographics Patent Drafting Services. *Technical Illustration.*

<<http://www.patentdrafting.com/gallery.htm>>

Figure 6b. Wikimedia Commons. *RMT Patent Drawing.*

<http://commons.wikimedia.org/wiki/File:RMT-Patent_Drawing.gif>

Figure 7. Rite-Temp Manufacturing. *6022 ritetemp Operation Guide. 2008.*

Figure 8. CostPlus World Market Store. *Kona Outdoor Bar Assembly Instructions. 2008.*

Figure 9. Sears, Roebuck and Company. *Vacuum Cleaner Owner's Manual, Kenmore Model 116. 2008.*